

Volume 1, Issue 1

PRACTITIONER JOURNAL OF MATHEMATICS AND SCIENCE TEACHERS

FY 2021/2022

PJM&ST

A publication by
the Centre for
Mathematics,
Science and
Technology
Education in
Africa
(CEMASTEА)

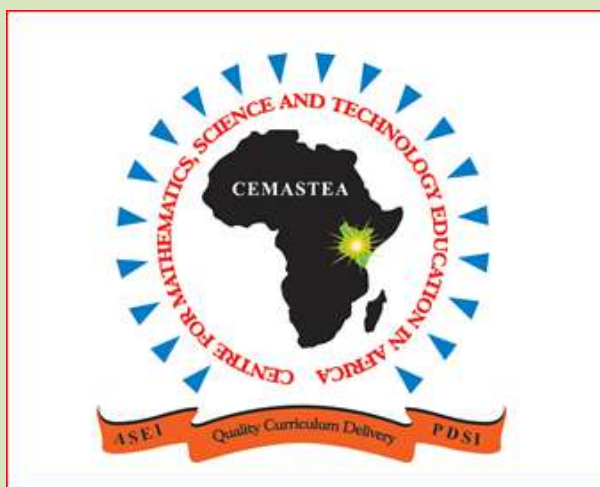

Kenya (Kenya flag) **VISION 2030**



Centre for Mathematics, Science and Technology Education in Africa (CEMASTE)

P. O. BOX 24214-00502 Karen – Bogani-Karen Roads Junction, NAIROBI – KENYA

Phone: +254-20-2044406; +254-0706-722697/0780-797648

E-mail: director@cemastea.ac.ke

Website: <https://www.cemastea.ac.ke/>

PRACTITIONER JOURNAL OF MATHEMATICS AND SCIENCE TEACHERS

Volume 1, Issue 1

Research & Development Department

All rights reserved
© CEMASTE, 2022

About the Journal

Practitioner Journal of Mathematics and Science Teachers (PJM&ST) is a publication of the Centre for Mathematics, Science and Technology Education in Africa (CEMASTEA). It is a journal for teachers and by teachers that aims at publishing original work in the form of theories, research, models, and experiences that teachers can draw from to support curriculum implementation and improve practice in mathematics and science education. This is in line with the aspirations inherent in the Kenya Vision 2030, particularly in the Education and Training sector of the Social Pillar.

PJM&ST is a peer-review journal that employs a double-blind review process. The following editorial Board members and technical officers supported the publishing of Issue 1, Volume 1 of the PJM&ST.

Editorial Board

Editor-in-chief

Mrs. Jacinta L. Akatsa, HSC - Director, CEMASTE A

Editorial Board

Mungai Njoroge, Ph.D. – Coordinator Research & Development Department, CEMASTE A
Ms. Agnes Mwangi – Deputy Coordinator Research & Development Department, CEMASTE A
Mrs. Beatrice Macharia – Member Research & Development Department, CEMASTE A
Mr. Joseph K. Thuo – Member Research & Development Department, CEMASTE A
Ms. Clotilda Murambi – Member Research & Development Department, CEMASTE A
Mr. Joseph Kuria – Member Research & Development Department, CEMASTE A
Mrs. Gladys Masai – Chemistry Department, CEMASTE A
Mr. Livingstone J. Makanda – Physics Department, CEMASTE A
Mr. Kizito Makoba – Biology Department, CEMASTE A
Ms. Rahab Chiira – Mathematics, CEMASTE A
Dr. Grace Orado, Ph.D. – Kenyatta University
Mr. Simon Mururi – Ministry of Education
Mr. Kennedy Otieno – Teachers Service Commission

Technical support officers

Ms. Magdalene Kavuu - Member Research & Development Department, CEMASTE A
Ms. Iqra Galgalo - Member Research & Development Department, CEMASTE A
Mr. Davis Wamalwa – Member Research & Development Department, CEMASTE A
Mr. Charles Karani – ICT Department, CEMASTE A

This first Issue of the PJM&ST is published on CEMASTE A's Website and e-Portal. Plans are in progress to transition the publication of the PJM&ST on an Online Journal System (OJS) platform. The International Standard Serial Number (ISSN) registration for the PJM&ST is in progress.

On behalf of CEMASTE A and myself, I wish you a happy reading of Volume 1 Issue 1 of the PJM&ST. I take this opportunity to invite all practitioners in the Education and Training Sector to support the PJM&ST by contributing articles for the upcoming Issues and Volumes

Jacinta L. Akatsa, HSC - Director, CEMASTE A

Table of Contents

Title page	ii
About the journal	iii
Table of Contents	iv
Synopsis of Volume 1, Issue 1	1
Expanding Instructional Spaces for Biology: The Role of "Talking Walls"	2
<i>Joseph Karanja Thuo</i>	
Learners' Unique Responses: Can they be used to Promote Learning?	6
<i>Rahab Chiira & Agnes Mwangi</i>	
Modelling how to Elicit Learners' Ideas	11
<i>Grace N. Orado</i>	
Demonstrating the Critical Angle and Total Internal Reflection Using a Laser Beam	15
<i>John Kiplimo Chumo</i>	
The Magic of "Prerequisite Knowledge" in Meaningful Learner Engagement	18
<i>Hilliard Peter Kiwaza Righa</i>	
It Can be Done: Innovative Biology Practical Activities that Learners Can Identify with	22
<i>Kennedy Kivonya</i>	
An Interpretation of Universal Design for Learning and its Application in the Competence-Based Curriculum	25
<i>Mungai Njoroge</i>	

Synopsis of Volume 1, Issue 1

Centre for Mathematics, Science and Technology Education in Africa (CEMASTEA) is pleased to share with you articles published in Issue 1 of Volume 1 of the Practitioner Journal of Mathematics and Science Teachers (PJM&ST). The articles published in the PJM&ST are written by teachers who are practitioners in the education and training sector.

Issue 1 of Volume 1 publishes seven articles that address various issues of practice pertinent to enhancing the quality of education, which is pertinent to supporting Education and Training Sector envisioned in the Social Pillar of Kenya Vision 2030. The articles highlight some issues related to Sustainable Development Goal 4 (SDG 4) that aims to “ensure inclusive and equitable quality education and promote lifelong learning opportunities for all” by 2030.

The *Expanding Instructional Spaces for Biology: The Role of "Talking Walls"* article by Joseph Karanja Thuo emphasizes the role of the teacher in ensuring that students reap maximum benefits from 'Talking walls' in their schools. The *Learners' Unique Responses: Can they be used to Promote Learning?* article by Rahab Chiira & Agnes Mwangi encourages teachers to draw on learners' unique responses and use them to promote learning. The article on *Modeling how to Elicit Learners' Ideas* by Grace N. Orado calls on teachers to seek to understand learners' ideas, the thinking behind those ideas, and leverage learning based on those ideas. The article titled *Demonstrating the Critical Angle and Total Internal Reflection Using a Laser Beam* by John Kiplimo Chumo shares an experience of designing an *Optical Model* for use in teaching the content on a critical angle and total internal reflection in physics. The *Magic of "Prerequisite Knowledge" in Meaningful Learner Engagement* article by Hilliard Peter Kiwaza Righa is a reflection from personal experiences depicting that prerequisite knowledge is vital if learners are to be fruitfully engaged in lesson activities. The article titled *It Can be Done: Innovative Biology Practical Activities that Learners Can Identify with* by Kennedy Kivonya is an appeal to teachers to come up with innovative activities and modified existing ones to make them learner-friendly for teaching Biology concepts. The article titled *An Interpretation of Universal Design for Learning and its Application in the Competence-Based Curriculum* by Mungai Njoroge shares an interpretation of UDL principles and gives examples of how to actualize them to support the inclusion of all learners in the learning process.

The ideas and opinions expressed in each of the articles are solely those of the individual author(s). The reader is welcome to contact the corresponding author using the address shared at the end of each article.

Enjoy the reading!

Mungai Njoroge, Ph.D. - Coordinator Research & Development Department, CEMASTEA

Expanding Instructional Spaces for Biology: The Role of "Talking Walls"

Joseph Karanja Thuo

Abstract

Illustrations or diagrams form an integral part of learning biology. They help learners to relate biological concepts to structures and their functions. 'Talking walls' or Murals are a form of illustrations typical in many schools. However, research shows that most Talking walls remain "pretty pictures" and are forgotten or underutilised in teaching. It is against this background that whenever I see 'Talking walls', my concern has always been on how teachers and students use them to improve learning outcomes. In this article, I describe two of the pictures from 'Talking walls' depicting ideas in biology I obtained from two different schools. I discuss the importance of having 'Talking walls' that accurately communicate ideas to avoid introducing misconceptions. I conclude the article by emphasising the role of the teacher in ensuring that students reap maximum benefits from 'Talking walls' in their schools.

Keywords

Instructional spaces; Murals; Talking walls

Introduction

The art of drawing is age-old. Early humans filled their prehistoric homes, mostly caves, with illustrations of their hunter-gatherer lifestyle. Most of the illustrations depicted animals, such as the one shown in Figure 1. While the purpose has not been clearly understood, these illustrations give insights into the development of the human mind and the hominids' ways of life. Most primary and secondary schools have 'talking walls' or murals. These are drawings or paintings on walls outside the classrooms conveying educational information. While visiting schools to conduct training, collect data for research, or support teachers to implement ideas they learn during teacher professional development (TPD), I always take notice of the Talking walls in several schools. As a biology teacher, my attention is always drawn to murals representing concepts in biology. I take pictures of those murals, and while doing so, one question that constantly runs in my mind concerns how the Talking walls are used to support learning. This paper describes my reflections about my observations regarding murals, in this case, two examples, and how teachers and students can put them to use to improve learning outcomes.

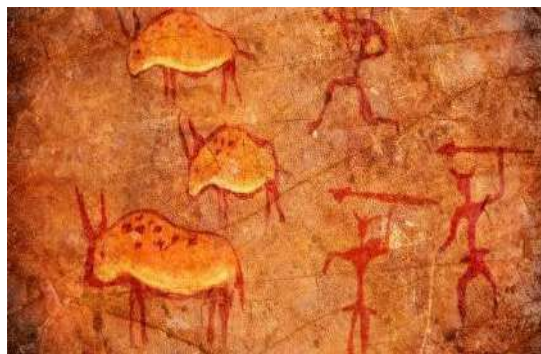

Figure 1: A wall from a pre-historic home
Source: Royal Academy of Chemistry (2021)

Illustrations in Biology

Biology is a subject that has many illustrations or diagrams. From the topics' *Cell and Cell Physiology*', in Form One to the Topic '*Support and Movement*', in Form Four, the learner is taken

through several illustrations that include simple diagrams such as the 'simple cell' to complex ones such that of the 'heart' and 'nephron'. Illustrations form an integral part of the learning process, and most textbooks contain illustrations to aid in visualising concepts and, by extension, learning. Illustrations and biological drawings help learners relate biological structures and their functions. For example, a learner may not fully understand the heart's pumping mechanism if they had not interacted with its diagrammatic representation and understands its general structure and functions. For some concepts, learners need to know the structure and function of specific parts of a biological structure or system. This may not happen if they are not given opportunities to interact with these structures through realia, modelling, or use of Information Communication Technology (ICT) that include pictures, videos, and illustrations.

“Talking Walls” Illustrating Concepts in Biology

Whenever I come across 'Talking walls' representing biology ideas in the schools I visit, I take their snapshots. From most photographs, it is clear that great effort and thinking go into developing ideas for “Talking walls” in schools. From my assessment, most of the “Talking walls” are excellently done and are also educational. Furthermore, they are located at strategic positions in the school to enable students to interact with the content easily. Among the ones I have captured illustrating biology content, the majority are proportionate and representative of the different ideas in various topics in the biology syllabus being depicted. They include labelled parts of the biological structures they represent, with the majority having been done in colour. An example of a well-done mural is shown in Figure 2. The mural, which depicts man's digestive system, shows clearly labelled, curriculum-relevant parts of the digestive system.



Figure 2: A mural showing the digestive system of man

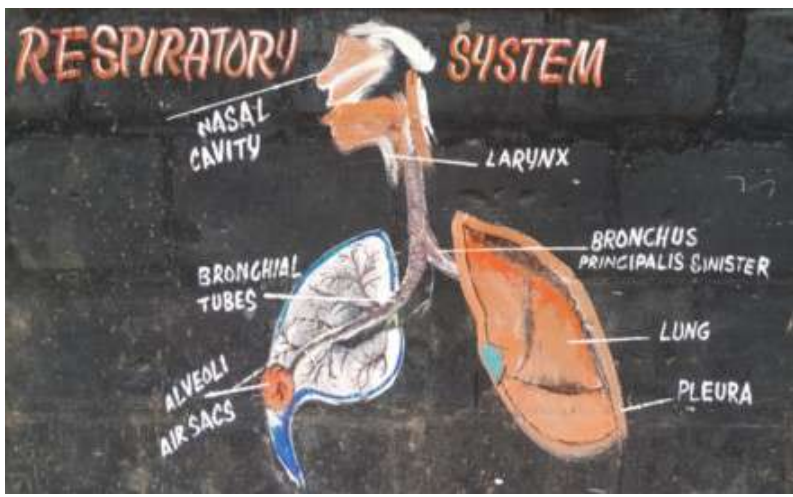

Figure 3: A mural showing the respiratory system of man

However, there are 'Talking walls' or biological illustrations that are poorly done and present misleading information that can result in misconceptions. Figure 3 shows an example of such a mural. The figure is a mural representing the respiratory system in man. Although it is done in colour, which helps to catch the eye, it shows several aspects that misrepresent the respiratory system's content.

For example, the lungs are slanted towards the left with apparent differences in the symmetry of the two lungs (e.g., the left lung, which shows a cross-section of the lung, looks like a leaf with a network venation with a pointed lower bottom end while the right lung is curved at the bottom).

Furthermore, the alveoli air sacs appear like they are an independent structure on or beside the lungs. Equally, the labels are done poorly. For example, the larynx and the nasal cavity labels are pointed at the voice box and nose, respectively, instead of the actual structures. In addition, it is not clear why the label '*principalis sinister*' is included in this drawing. This is because the content involving this terminology is above the level of secondary biology. Overall, this mural is misleading and, therefore, unlikely to help enhance the understanding of ideas involved in the respiratory system.

"Talking Walls" as Instructional Spaces

As I take pictures of 'talking walls', my concern has always been their use as a resource to enhance learning. Teachers should always endeavour to select instructional materials and activities that stimulate students' thinking and facilitate effective learning. Furthermore, learning should be interactive and fun. The starting point for such fun could be schools 'talking walls'. 'Talking walls' can enhance learners' interest in a given subject because they provide a visually stimulating environment. As a result, the walls are likely to promote positive learner attitudes toward learning. For the 'talking walls' to effectively facilitate meaningful learning, they need to be designed well and organised. They should also be accurate representations of the ideas being conveyed. According to Catapult Learning (2018), the walls should be designed and organised to provide crucial instructional information for students with multiple learning, thinking, and writing opportunities. Bennett (2019) noted that the educational value of many wall paintings remains underutilised since most of them are forgotten "pretty pictures" on the walls. This means that teachers have a role to play in this process.

Teachers should ensure that 'talking walls' are designed to arouse students' interest provoke their thinking in the subject, and effectively communicate the ideas being conveyed. In addition, the teacher must be selective about the number of wall paintings, types, kinds and sizes, quantity and quality of labels, and explanatory texts. Further, the positioning of murals in the school compound for students to reap maximum benefit should be at a location with a more learner footprint. The teachers should also play an active role in guiding students to use the 'talking walls'. Where possible, teachers should make deliberate efforts to conduct lessons involving ideas depicted by murals near such murals and guide the students in understanding the concepts involved. Assessment could also be based on the murals.

Conclusion

Many primary and secondary schools have 'Talking walls' intended to enhance the understanding of biological concepts depicted. While some of the 'Talking walls' are professionally done and therefore can effectively aid in meaningful learning, others can propagate misconceptions of the ideas they are supposed to illustrate. Talking walls' that aid the teaching and learning should be easy to use, colourful with clear and large labels, and without the clutter of explanations. Talking walls that are well-designed help capture and retain students' attention and motivate them to learn. To encourage learners to use the wall paintings for study,

teachers can employ a place-based learning instructional strategy and implement their lessons where the murals are. They also can set quizzes based on these illustrations.

References

- Bennett, C. (2019). Stop classroom clutter: Think before you paint or hang that poster. Retrieved July 31, 2021, from <https://www.thoughtco.com/decorating-your-classroom-4077035>
- Catapult Learning (2018). Building classroom walls that teach. Retrieved December 11, 2021, from <https://catapultlearning.com/2016/08/29/building-classroom-walls-teach/>
- Royal Academy of Chemistry (2021). Style in cave paintings Retrieved 5 December 2021 from Education, inspiring your teaching and learning at <https://edu.rsc.org/resources/style-in-cave-paintings/1541.article>

Author Information

Joseph Karanja Thuo
Centre for Mathematics, Science and Technology Education in
Africa (CEMASTEА)
P. O. Box 24214 00502
Nairobi, Kenya
Email: jthuo@cemastea.ac.ke

Learners' Unique Responses: Can they be used to Promote Learning?

Rahab Chiira & Agnes Mwangi

Abstract

The use of learners' responses in teaching is important because it promotes active learning. It also enables the teacher to know the learners' thinking and reasoning. However, sometimes teachers do not know how to handle learners' unique responses, especially those they do not expect. The purpose of this article is to share information that can help teachers engage learners in meaningful learning by use of their unique responses as opposed to ignoring them. Using a reflection based on a lesson on the area of a trapezium, we discuss how a learner's unique response on the area of a parallelogram could be used to promote learning. In addition, we discuss how this idea could be extended to find the area of a trapezium. The article concludes with a call to teachers to draw on learners' unique responses and use them to promote learning.

Keywords

Active learning, Alternative ways of thinking, Deeper understanding, Unique responses

Introduction

In a classroom situation, teachers ask learners questions and expect certain responses. However, learners do not always give the expected responses. Rather, they give unique ones that could be correct or wrong. These responses are sometimes ignored because they are perceived to be wrong. Likely, teachers sometimes ignore learners' unique responses because they do not know how to adopt such unexpected responses in the current lesson. Unique responses given by learners are their ideas that can be used to promote active learning. The use of learners' ideas also ensures that they are engaged meaningfully in learning thus promoting inquiry as opposed to giving learners formulae and procedures to follow while solving problems. Through this article, we reflect on how a lesson on the area of a trapezium observed by the first author progressed and show missed opportunities for helping the students to learn meaningfully. We also discuss how learners' unique responses can be extended to help them develop a deeper understanding of the concept of the area of a trapezium.

The Lesson on the Area of a Trapezium

This lesson was conducted in Standard Seven in one of the primary schools in Kenya. The teacher began by stating the following, "Yesterday we learned about the area of a parallelogram. What did we say about the area of a parallelogram?" The learners raised their hands and one after the other gave their responses. Some of the learners' responses were: "length \times width", "it has two sharp sides", "it has a dotted line". This continued until one learner gave the answer the teacher expected (i.e. "base \times height"). The teacher reinforced the learner and continued with the lesson. None of the other learners were allowed to explain their answers.

Our Reflection

The way this lesson began makes us wonder whether the teacher knew that learners' unique responses should not be ignored, whether correct or wrong. In addition, was the teacher aware that learners' unique responses could be a good opportunity to promote alternative ways of thinking and therefore enhance learning? Furthermore, was the teacher aware that allowing the learners to explain their answers could help detect a misconception that can be mitigated during the lesson?

Indeed, some of the answers the teacher ignored were correct while others indicate that the concept of area and particularly the area of a parallelogram was not well understood by some of the learners. The concept to be taught during this lesson was the area of a trapezium. However, the concept of the area of a parallelogram is a prerequisite for the understanding area of a trapezium. Therefore, the teacher needed to interrogate the learners' responses further. This would have helped her know why learners gave those responses and thus reorganize the lesson to help them understand the target concept and ensure that any misconception(s) are not carried forward to future learning.

As the lesson progressed to the development stage, the teacher asked learners to look at a diagram of a trapezium in one of the textbooks. The teacher then posed the following question; "What is the difference between a parallelogram and a trapezium?" Given that the teacher had previously ignored some of the learners' responses, no learner raised his/her hand to respond. Thus, the teacher went ahead and answered the question then continued with the lesson. He used two diagrams of a trapezium to give the formula for the area of a trapezium as shown in Figure 1.

The teacher derived the formula and then explained it to the learners who sat quietly listening. The teacher did not encourage the learners to give their ideas on how to derive the formula for the area of a trapezium. At this point, it was clear that some of the learners were not together with the teacher as they wore faces of boredom. All the same, the learners were asked to copy in their notebooks what the teacher had written on the blackboard before concluding the lesson.

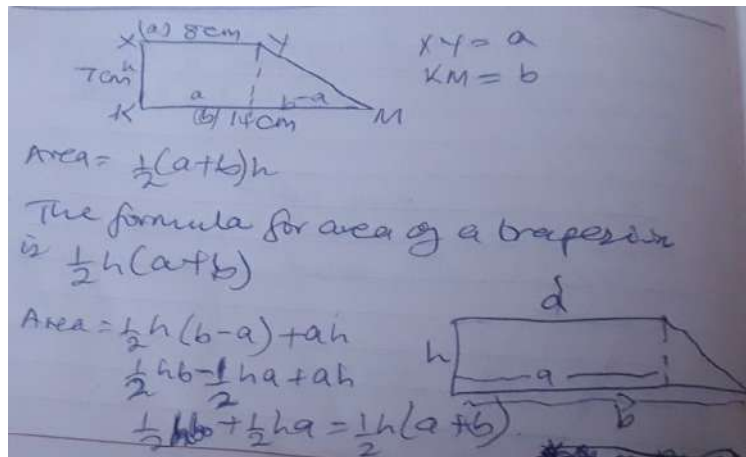

Figure 1: The teacher's work on the Area of a trapezium

Using Learners' Unique Responses to Support their Learning.

Quite often, teachers overlook learners' responses that are different from their expectations – those arrived at using different procedures and wrong ones; while correct answers are reinforced (Metcalf, 2016). Reinforcing a correct response is an indicator that the teacher is the authority

who gives rewards and does not allow the learners who give wrong responses to reflect, re-examine and re-assess their thought processes (Stevenson & Stigler, 1992). Consequently, learners who give wrong responses feel discouraged and may lose interest or shy away from active learning. It is important to allow learners to explain their answers because it creates a learning opportunity for the learner and it also promotes learning for others. Furthermore, it points out how a learner is thinking about the question asked and provides valuable feedback to the teacher. Indeed, unique responses given by learners could be as a result of teaching and learning methods used by the teacher, as well as learners' way of understanding and reasoning (Amalina & Jupri, 2017).

In the lesson on the area of a trapezium, one of the responses ignored was unique, that is, the area of a parallelogram is determined by the formula *length x width*. The teacher expected the response *base x height*, but is the response *length x width* necessarily incorrect? The teacher should have allowed a class discussion to interrogate this response to elicit the learners' alternative ways of thinking. The learner who gave this response could have been allowed to explain his thinking and engage others in a discussion to understand that thinking. Ideally, the formula for finding the area of a parallelogram is derived from the area of a rectangle as shown in Figure 2.

In the diagram, a triangle ABE is cut off from rectangle ABCD and attached to line DC, the figure obtained is a parallelogram whose base is equivalent to the length of the rectangle. Similarly, its height is equivalent to the width of the rectangle. Using this illustration, the learners can understand how a rectangle can be transformed into a parallelogram and the relationship between their areas, hence the unique response of *length x width*.

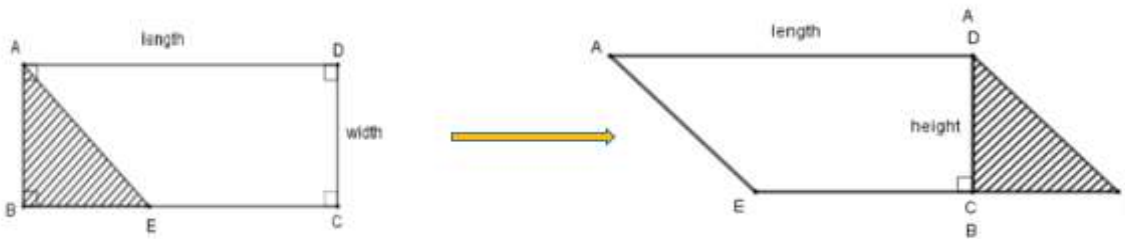

Figure 2: Formula for finding the area of a parallelogram

Extending Learning using Learners' Unique Responses

From the unique response discussed above, the teacher should now be able to guide the learners to link the prerequisite knowledge to the current knowledge to be taught as well as to future knowledge. For example, the knowledge on how to derive the formula for the area of a parallelogram can be developed further to derive the formula for the area of a trapezium. We illustrate this using Figure 3.

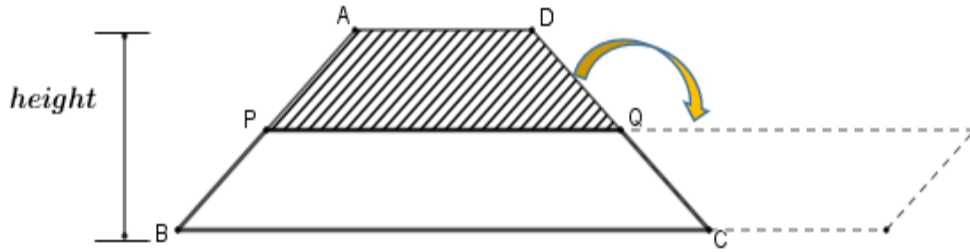

Figure 3: A transformed trapezium

Figure 3 shows trapezium ABCD with side AD parallel to BC. The formula for the area of the trapezium can be derived from the prior knowledge on the area of a parallelogram as seen from the previous section. This can be done by drawing line PQ equidistant to the parallel lines AD and BC to form two trapezia whose height is half the height of the original trapezium. If trapezium APQD is moved to the right and inverted as shown in Figure 3, the resulting figure is a parallelogram (see Figure 4).

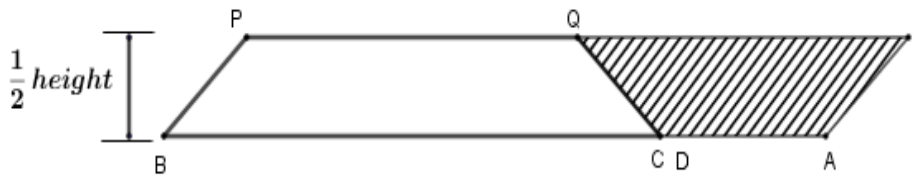

Figure 4: Formula for finding the area of a trapezium

The area of the transformed trapezium is equivalent to the area of the resulting parallelogram in figure 4 above. This is given by;

$$\text{Area of trapezium} = \text{area of resulting parallelogram} = \text{base} \times \text{height} = BA \times \frac{1}{2} \text{ height}$$

But the base $BA = AD + BC$, and the $\text{height} = \frac{1}{2} \text{ height}$. Hence;

$$\text{Area of trapezium} = (AD + BC) \times \frac{1}{2} \text{ height} = \frac{1}{2} (AD + BC) \text{ height}$$

From this example, it is clear that learners' unique responses can promote alternative ways of thinking and enhance a deeper understanding of mathematical concepts, and therefore such should not be ignored.

Conclusion

In this article, we have reflected on how one lesson targeting learners to understand how to determine the area of a trapezium progressed. We have shown how one response given by a learner at the initial stage of the lesson was ignored and yet, the teacher could have drawn on it to support learners and extend their understanding. To ensure that learners are engaged in meaningful learning throughout the lesson, a teacher needs to anticipate learners' responses. This helps the teacher plan how to deal with learners' unique responses during the lesson. It also helps the teacher to be able to address misconceptions that may arise. This can be done by allowing the learners to not only present and explain their ideas but also to correct their mistakes as well as

learn from each other's mistakes. The teacher can then lead the learners to conclude using their unique ideas.

References

- Amalina, E. N., & Jupri, A. L. (2012). Analysis of students' incorrect answers at scale materials in the Fifth-Grade of primary school. *Journal of Physics Conference Series*, 812(1), 1-7.
- Chin, C., & Osborne, J. (2008). Students' questions: A potential resource for teaching and learning science. *Studies in Science Education*, 44(1), 1-39. doi:10.1080/03057260701828101
- Curwin, R. (2014). It's a mistake not to use mistakes as part of the learning process. Retrieved January 11, 2022, from <https://www.edutopia.org/blog/use-mistakes-in-learning-process-richard-curwin>
- Metcalf, J. (2017). Learning from errors. *Annual review of psychology*, 465-489. doi:10.1146/annurev-psych-010416-044022
- Stevenson, H., & Stigler, J. W. (1992). *The learning gap: why our schools are failing and what we can learn from Japanese and Chinese education*. Simon & Schuster, New York: NY

Author Information

Rahab Chiira & Agnes Mwangi
Centre for Mathematics, Science and Technology Education in
Africa (CEMASTE A)
P. O. Box 24214 00502
Nairobi, Kenya
Email: rchiira@cemastea.ac.ke

Modelling how to Elicit Learners' Ideas

Grace N. Orado

Abstract

As teachers participate in Teacher professional development (TPD) programs, one of the greatest concerns is whether they implement what they learn. Teachers are likely to practice what they learn when they find it not only practical but also if they can relate to it. Working as a teacher trainer during the 2016 secondary program INSET by CEMASTEIA, I modelled to teachers how they can elicit learners' ideas, I designed an activity where I prompted the teachers to think about and state what they thought was in a bubble in boiling water. Working with teachers as learners, they experienced what it means to elicit learners' ideas as well as the varied responses they gave for what is contained in a bubble of boiling water. This article describes this activity and concludes with a call to teachers to seek to understand learners' ideas, the thinking behind those ideas, and leverage learning based on those ideas.

Keywords

Learners' ideas, Teachers as learners, Teachers' ideas

Introduction

Learners have ideas about concepts they learn in class. Effective teaching should endeavor to build on these ideas to leverage meaningful learning (Taber, 2014). Therefore, teachers' understanding of how to elicit and build on learners' ideas is key. In this article, I describe, the outcome of an activity I used during the 2016 secondary teacher professional development (TPD) in-service education and training (INSET) to help teachers appreciate the variation in thinking among individuals on the granted common phenomenon.

Teachers as Learners

The Unit titled "*Encouraging, Capturing and Using Learners' Ideas*" was included in the 2016 Secondary INSET Module to help the teachers not only understand that learners have ideas about content they teach but also help them to develop strategies for soliciting and using learners' ideas in teaching. As one of the facilitators of the content in this unit, my struggle was on how to enhance participating teachers' understanding of how to elicit ideas that learners have about concepts before the actual teaching in class. After reflecting on this for some time, I decided to position teachers as learners and elicit their understanding of a given phenomenon. This was guided by the understanding that teachers learn and implement what they learn better if they can relate to it (Patton, Parker & Tannehill, 2015). I designed and used an activity that allowed teachers to think about and state what they thought was in a bubble in boiling water. I chose a bubble in boiling water because it is a common phenomenon that is familiar to many people.

1. Activity on a Bubble in Boiling Water

During the session, I projected one of the PowerPoint slides showing a picture of boiling water in a beaker over a Bunsen flame as shown in Figure 1. I then posed the question, "What is in the bubble in the boiling water?"

While the participants were still thinking, I provided them with blank cards and informed them that I would give them about two minutes to think about their idea and write their responses on the card provided without indicating their names. The idea of not writing their names was meant to allow them to give their responses freely without the fear of being linked to given responses individually. After two minutes, I collected the cards from the teachers.



Figure 1: Boiling Water in a Beaker

2. The Teachers' Responses

There were many different responses given by the teachers. The responses included drawings that represented the teachers' ideas as shown in Figure 2. All three drawings in Figure 2 show a bubble conceptualised as being a spherical enclosure containing air. This means that the teachers who drew their ideas as shown in Figure 2 visualised the bubble as a ball-like structure containing air.



Figure 2: Drawings of "what is in a bubble of boiling water"

From the written responses, I randomly selected and shared a few of the responses. The teachers were surprised to learn that there were as many different ideas of what is contained in the bubble in boiling water as there were participants in the session.

At the end of the session, I took the cards with me for further analysis. I sorted and categorised the responses into two main categories namely matter and non-matter. Examples of responses in the matter category were "air", "steam", and "oxygen". On the other hand, examples of responses in the non-matter category were

"pressure" and "energy". I further categorised the responses in the matter category into two sub-categories as follows (1) known gaseous substances (2) unknown gaseous substances. Table 1 shows categories and sub-categories of the teachers' responses as well as the number and percentage of respondents per category and sub-category.

Table 1: Teacher's responses by category and sub-category

Category	Sub-category	Exemplars	Respondents	%
Matter	Known gaseous substances	Air, hot air,	105	60.0
		Water vapour, steam	26	14.9
		Air and water vapour	20	11.4
	Unknown gaseous substances	Hydrogen and oxygen, Oxygen	3	1.7
Non-matter		Gasses, gas	15	8.6
		Vacuum, pressure, heat energy	6	3.4
Total			175	100

Based on data in Table 1, 96.6% of the teachers thought that a bubble in boiling water contained substances that can be considered to be matter with the majority (i.e., 60% of the total respondents) indicating that the bubble contains air. It is interesting to note that a small percentage (i.e., 3.4%) of the teachers thought that the bubble had no matter in it including the idea that there was completely nothing (i.e., vacuum) in the bubble.

Ideas and the Thinking behind them

This activity is a clear demonstration that people including teachers can have different ideas about even the taken-for-granted phenomena such as a bubble in boiling water. It is for this reason that teachers should give learners opportunities to express their ideas about the content being taught, draw on those ideas and support them to learn. Teachers can use this strategy of presenting a phenomenon to students and asking them to think and give their ideas and understanding about it. It may not be necessary for teachers to carry out a detailed analysis of their learners' ideas as described in this article. However, they need to understand the thinking behind learners' ideas. This can be achieved by selecting some of the responses and probing the students to provide the likely reasoning and thinking behind those responses. This way, the students will have opportunities to not only give their ideas but also reflect on the thinking behind their ideas. As a result, the students become and remain active participants in their learning which is a major expectation of the Competency-Based Curriculum (CBC).

Using the example of the teachers' ideas as shown in Table 1, some possible explanations for their ideas include, (1) water contains dissolved air that is expelled as bubbles during boiling for those who indicated that a bubble contains air; (2) water molecules vibrate faster when boiled and turn into water vapour or steam that rises in the boiling water as bubbles for those who indicated that a bubble contains water vapour or steam; and (3) heat breaks water molecules into its constituent elements (i.e., hydrogen and oxygen) for those who indicated that a bubble contains hydrogen and oxygen or oxygen alone. The scientific accurate thinking, in this case, is the second one. Therefore, making the students' thinking visible helps the teacher to recognise misconceptions in their thinking. Ultimately, this can help the teacher to design further activities to support or challenge students' thinking as they work towards a more acceptable explanation of the phenomenon.

Conclusion

The purpose of TPD is to help teachers improve their teaching methodologies for improved students' learning outcomes. I designed an activity where I prompted the teachers participating in the 2016 Secondary program TPD to think about and state what is in a bubble in boiling water. This was to help them to come to recognise and appreciate that learners' have ideas about the

content they learn in class. The activity also sought to help the teachers understand that while some of the ideas may be closer to the acceptable reasoning behind the content, others are not. This activity showed that even teachers can hold different ideas about the simplest and most common phenomenon such as a bubble in boiling water. Teachers need to determine ideas students have about the content they teach and leverage their learning based on those ideas. The teachers need to be flexible and accept students' responses in whatever format including written text, verbal submissions, and drawings. Drawing is especially important as Ainsworth, Prain, and Russell (2011) argue it is not only a learning strategy but also helps in representing and communicating ideas and enhances engagement.

References

- Ainsworth, S., Prain, V., & Russell, T. (2011). Drawing to learn in science. *Science*, 333(6046), 1096–1097.
- Patton, K., Parker, M., & Tannehill, D. (2015). Helping teachers help themselves: Professional development that makes a difference. *NASSP Bulletin*, 99(1), 26–42.
<https://doi.org/10.1177/0192636515576040>
- Taber, K. (2014). *Student thinking and learning in science: Perspectives on the nature and development of learners' ideas*. Taylor & Francis, NY: New York.

Author Information

Grace N. Orado
Kenyatta University
P. O. Box 43844 00100
Nairobi, Kenya
Email: orado.grace@ku.ac.ke

Demonstrating the Critical Angle and Total Internal Reflection Using a Laser Beam

John Kiplimo Chumo

Abstract

This article demonstrates my experience as a Physics teacher and the challenges I faced when guiding learners to experiment to understand what a critical angle is, and the conditions necessary for total internal reflection to occur. In the article, I have also shared how I overcame these challenges by designing an *Optical Model*. Further, I have also shared the benefits of the model against the existing and recommended apparatuses as listed curriculum materials that include the syllabus and textbooks. Given its advantages in aiding learning, I strongly recommend its use in teaching the content on a critical angle and total internal reflection in physics.

Keywords

Critical angle, Laser beam, Optical model, Refraction, Total internal reflection

Introduction

Critical Angle and Total Internal Reflection are concepts taught in Form Three in the Kenya Secondary School curriculum under a topic called Refraction of Light (Kenya Literature Bureau, 2017). The concepts are necessary for explaining how devices such as prism binocular, pentaprism and optical fibres work. Sometimes, learners find it challenging to understand why and how light can be refracted and reflected internally by a material when the critical angle is exceeded. This problem is compounded by the nature of the learning materials recommended in the syllabus and textbooks. The materials provide the guideline of using optical pins and a ray box. However, the two options provided by the syllabus have weaknesses. For example, while using the optical pins, a learner is required to hold the glass block closer to one eye. Unfortunately, learners suffering from long-sightedness will not make any observation of the pins' images. The ray box, on the other hand, produces scattered rays of light which makes it hard to trace the path travelled by the refracted ray. Additionally, using a ray box requires that the experiment is done in a dark room; obtaining this during the daytime is challenging in a normal school laboratory. Handling learners in a dark room compromises their safety too. In this article, I describe how I overcame these challenges by designing a teaching model called the *Optical Model*.

Teaching the Content on Critical Angle and Total Internal reflection

One day, I was guiding learners in the laboratory to experiment to demonstrate what a critical angle " C " is and the conditions necessary for the occurrence of total internal reflection. In optics (which is a branch of Physics) a critical angle is the angle of incidence in an optically dense material (for example glass) whose angle of refraction in an optically less dense material (for example air) is 90° .

Initially, I used four optical pins and a semi-circular glass block. However, some learners who were long-sighted could not trace the images of the optical pins. This is because, for one to view the images of the optical pins, one has to hold the semi-circular glass block closer to the eyes. Questions from students such as "what am I supposed to see?" or statements such as "I cannot see

anything” indicated that the apparatus used did not favour all learners since the desired outcome was not achieved. As a concerned teacher, I resorted to another alternative, I replaced the optical pins with a Ray Box. Unfortunately, the ray box failed because it produced a divergent beam of light that could not be focused on a screen to show total internal reflection.

To address this challenge, I designed an *Optical Model*. This is bearing in mind that applications of teaching models in physics reinforce learners’ understanding of scientific concepts. Further, the teaching models are crucial in clearing up misconceptions and increasing learners’ ability to apply concepts in real-life situations (Archer & Ng, 2016; Shahan & Jenkinson, 2016). In addition, the learning models in physics can be used to demonstrate the link between theory and practice (Korsun, 2017). Figure 1 is a diagrammatic representation of the Optical Model which I designed to enhance the understanding of the two concepts.

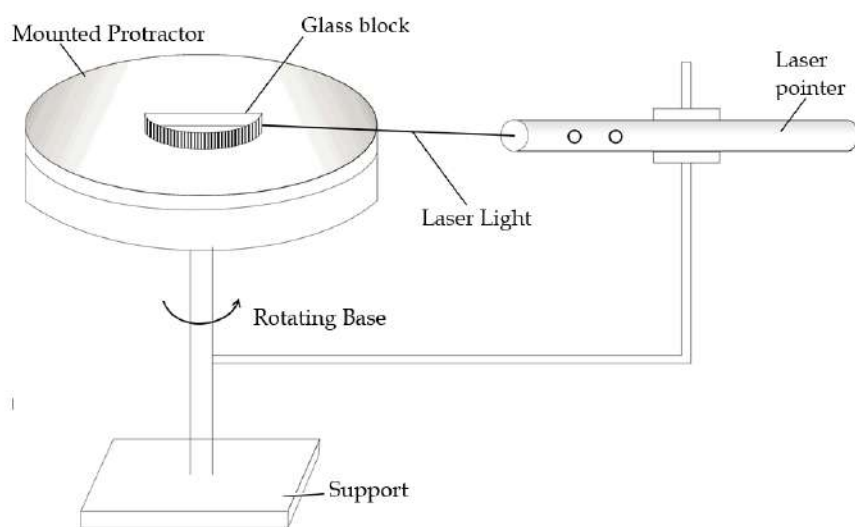

Figure 1: Optical Model

The model is fitted with a semi-circular glass block and protractor where both are mounted on a rotating base. Further, a fixed laser pointer is attached to the model as a source of light.

How the Optical Model Works

The incident light from the laser pointer is cast on the curved side of the semi-circular glass block such that the laser light goes through the normal (an imaginary line that is perpendicular to the glass surface). The rotating base is slowly rotated so that the angle of incidence is slowly increased from 0° . The rotation of the base is done until the angle of refraction in the air is 90° . At this point, the critical angle, C , is obtained. When the critical angle is exceeded by rotating the base further, the light is fully reflected by the glass block. As such, the phenomenon of total internal reflection is easily observed. To understand more how the Optical Model works, watch a short video clip available at https://youtu.be/k6Wo_uWMeeM.

Benefits of using *Optical Model* over the Optical Pins and a Ray Box

The following are the benefits of using the Optical Model over optical pins and the Ray box.

- *The Optical Model* uses laser light which is focused (non-scattered). As a result, it clearly shows the path of light as it moves from glass to air; showing clearly the critical angle ‘ C ’ in a glass when the angle of refraction in the air is 90° .
- When the critical angle is exceeded, the reflected light (as a result of total internal reflection) is visible on the screen mounted on the model.
- The protractor which is also mounted on the model makes it easy to measure the angle of incidence and angle of reflection of light in glass.

- Further, since the laser light is coloured (red or blue), the model makes it possible to experiment without the need of creating a darkroom in the laboratory.
- In addition, as opposed to the use of optical pins which must be held close to the eyes, learners who are long-sighted can easily make observations using the *Optical Model*.
- Additionally, the *Optical Model* is a unit system and light. This makes it easy to use and carry around.

Conclusion

The beauty of learning physics lies in its ability to explain complex ideas in the simplest ways. In this article, I have described how this can be achieved by using the Optical Model in Refraction. By using the Optical Model, learners will have an opportunity to see, touch, and feel what they are learning by interacting with this model. On the other hand, the model simplifies the work of the teacher. This is because learners' involvement in the learning process is enhanced by interacting with the model. As such, I highly recommend its application as a way of simplifying the understanding of what a critical angle is, and the conditions necessary for total internal reflection to occur.

References

- Archer, L. A. C., & Ng, K. E. (2016). Using the scientific method to engage mathematical modelling: An investigation of pi. *Journal of Education in Science, Environment and Health*, 2(1), 51-56.
- Kenya Literature Bureau (2017). *Secondary Physics Students' Book Three*. Kenya Literature Bureau. Nairobi.
- KNEC [Kenya National Examination Council] (2018). Kenya national examination council report 2018. Nairobi: Kenya National Examination Council.
- Korsun, I. (2017). The use of the interdisciplinary approach for the formation of learners' situational interest in Physics. *Asia-Pacific Forum on Science Learning and Teaching*, 18 (2), 1-15.
- Shahan, V. M., & Jenkinson, J. (2016). The efficacy of interactive analogical models in the instruction of bond energy curves in undergraduate chemistry. *Chemistry Education Research and Practice*, 17(2), 417-428.

Author Information

John Kiplimo Chumo
 Chebara Girls Secondary School-Marakwet
 P. O. Box 7755 - 30100
 Eldoret, Kenya
 Email: johniechumo@gmail.com

The Magic of “Prerequisite Knowledge” in Meaningful Learner Engagement

Hilliard Peter Kiwaza Righa

Abstract

Topics learned in different science subjects are related. Some concepts are built from one to another starting at a lower level to a more advanced level in education. Many teachers experience frustration when they take time to plan for a lesson only to go to class and struggle engaging learners in the lesson activities. In my reflective practice from my experiences, I have found that prerequisite knowledge is vital if learners are to be fruitfully engaged in lesson activities. For example, I realised that learners could not do activities on the preparation of molar solutions taught in chemistry Form Three because they lacked knowledge of chemical formulae, taught at Form Two. When I planned the lesson on Molar solutions and integrated a revision of chemical formulae, I noted that the students were engaged and participated actively in the lesson.

Keywords

Learner engagement, Prerequisite knowledge, Prior planning

Introduction

The ultimate goal of every teacher in a given lesson is to enable all learners to get involved in activities that should eventually lead to learning. It becomes worrying to teachers if they find out that some learners do not take part in the lesson activities for whichever reason. Most teachers usually resolve to spend a considerable amount of the lesson time in solving problems they think are making learners not participate in lesson activities. This means that the teacher is unlikely to achieve the lesson objectives as a result of a shortage of time.

The real nightmare comes when learners are unable to participate in the lesson activities because they lack an understanding of a concept that they ought to have learned earlier. In other words, such learners lack the prerequisite knowledge (PK). There is a need therefore for teachers to carefully consider prerequisite knowledge when planning for their lessons. Toh and Kapur (2017) assert that prerequisite knowledge influenced learners in their lesson involvement.

The Role of Prerequisite Knowledge

“Molar solutions” is a sub-topic under the topic “The Mole” in Form Three of the Secondary school level. Learners are required to understand and carry out calculations involving Molar solutions. They are also required to prepare molar solutions. This can be achieved if learners have a knowledge of chemical formulae which is content taught at Form Two.

One day I went to class prepared to teach learners how to prepare Molar solutions using the demonstration method. I demonstrated how to prepare a 1 M solution of Sodium Hydroxide using solid Sodium Hydroxide. I also showed the learners all the calculations involved especially in determining the mass and moles of Sodium Hydroxide required to be dissolved to make 1 litre of solution. In my thinking, the lesson went well because most of the learners answered my questions as we worked on a few examples on the chalkboard. I noted that a fairly good number

Table 1. A Summary of Students' performance in class and test

		Correct	Wrong	Total
Lesson Score	No provision of PK	19	27	46
	PK provided	41	5	46
Test Score	No provision of PK	7	39	46
	PK provided	45	1	46

From the data in Table 1, I noted that when no PK was provided, there were learners who got some questions correct during the lesson activities but got the same questions or similar questions wrong during the test. This could probably suggest that such students copied from others during the lesson. It seems accurate to suggest that they may not have understood the concept. When prerequisite knowledge was provided there was an increase in the number of students who got the questions correct both during the lesson and the test.

Based on the observations during the two lessons on the same content, when a teacher prepares to teach a topic in which the learners lack prerequisite knowledge, learners may be superficially engaged in lesson activities. The students may find compensatory tricks of behaving as if all is well and this may send the wrong signal to the teacher who in turn may assume that meaningful learning is taking place. Correct answers to questions to the tasks given during the lesson are not a guarantee that learning is taking place.

To achieve a positive learning environment, attitude and motivation towards learning can be harnessed through ensuring the usage of appropriate instructional strategies (Chakraborty, 2017). In my view, prerequisite knowledge can be one of the strategies of motivating learners and ensuring that they learn meaningfully. This requires appropriate prior planning on the part of the teacher. This will help him/her realize meaningful learner engagement in learning (Taylor, Olofson, & Novak, 2017).

Conclusion

The importance of prerequisite knowledge as featured in this article cannot be overemphasised. If teachers can take time to focus on prerequisite knowledge, then they can get more learners involved in meaningful engagement in the learning process. Depending on the nature of the topic and the prerequisite knowledge required, teachers can plan and address it before the lesson. They can also address that by allocating more time during the lesson for the review of prerequisite knowledge.

Consequently, if not addressed, the lesson may continue and learners find tricky methods of indicating that all is well. The teacher may never know that learning is not taking place. Teachers can plan for lessons one or two days earlier and give their learners areas they require to review as take-away assignments. This will ensure that by the time the lesson is taught, the learners already have the required information to help them grasp the new topic. I call upon teachers to explore this area of taking into consideration prerequisite knowledge when planning for lessons. This will contribute to positive engagement in the learning process.

References

Chakraborty, M. (2017). *Learner engagement strategies in the online class environment*. Ph.D. Dissertation, Texas A&M University, TX.

- Taylor, A. T., Olofson, E. L., & Novak, W. R. (2017). Enhancing student retention of prerequisite knowledge through pre-class activities and in-class reinforcement. *Biochemistry and Molecular Biology Education*, 45(2), 97-104.
- Toh, P.L.L., & Kapur, M. (2017). Is having more prerequisite knowledge better for learning from productive failure? *Instructional Science*, 45(3), 377-394. <https://doi.org/10.1007/s11251-016-9402-0>

Author Information

Hilliard Peter Kiwaza Righa
Nguumo Girls' Secondary School
P.O. Box 229 - 90138 Makindu.
Makueni, Kenya
Email: righahilliard@gmail.com

It Can be Done: Innovative Biology Practical Activities that Learners Can Identify with

Kennedy Kivonya

Abstract

I taught biology for a long time in the usual way – textbook in hand and textbook prescribed activities were the norm. The result? Your guess is as good as mine. The students were bored and remained disinterested in the subject. I tried to come up with innovative activities – those that did not exist in biology textbooks and modified existing ones to make them learner-friendly. The results were amazing. My teaching has become easy and fun and my learners always look forward to that next lesson. I have purposed to continue exploring and coming up with more such activities. In this article, I share one such activity. I conclude the article with a call to teachers to try this strategy with their students.

Keywords

Innovative activities, Learner-friendly activities, Practical activities

Introduction

Biology like any other science should be taught through a practical approach. Teaching it otherwise erodes its scientific aspects and makes its content one that learners should partake of passively. I came to this realisation after many years of teaching biology where I disregarded the practical aspects of the subject. I was convinced beyond reasonable doubt that I was doing the right thing and always hid behind the excuse that certain concepts had no practical activities due to their abstract nature. The result of all these was a bored and disinterested group of students.

The turning point happened one day when the learners got fed up with my way of teaching and reported the matter to the principal. The principal summoned me to his office and asked me to change my way of teaching to ensure that students were engaged meaningfully in the teaching and learning process. This left me with no option but to reflect and reconsider my teaching approaches. From there henceforth I purposed to ensure that every lesson I taught, had practical activities conducted by the students. The following is a description of one of the activities I have used in teaching the concept of diffusion in biology.

The Concept of Diffusion

Diffusion is one of the concepts in secondary school biology. Students encounter this concept for the first time in Form One and one of the key ideas students need to learn and understand involves factors that affect the rate of diffusion. Interestingly; many recommended course books for biology have activities for demonstrating diffusion but none for investigating the factors of the process. For example, in the *Secondary Biology book* (KLB, 2017), there are two confirmatory activities used to demonstrate diffusion. In one of them, potassium manganate(VII) is used where learners observe diffusion as the purple colour spreads in water making the water turn purple. In the second activity, a visking tubing is used with starch and iodine solution to show diffusion, based on the concept of test for starch (p. 39-41). Unfortunately, the starch test is covered in the topic 'Nutrition' which comes after Diffusion. This makes the activity inappropriate for the Form One level.

In teaching about factors that influence diffusion, I came up with an activity the learners could identify with easily. I chose tea leaves because students are familiar with it. In one of the lessons where we needed to investigate the effect of the size of molecules and temperature on diffusion, we used coarse and fine tea leaves for the size of molecules and hot and cold water for temperature respectively. When we experimented, the differences in containers for the same factor (i.e., size of molecules or temperature) were visible for the same amount of time. Figure 1 shows the set-up and outcome of the experiment.

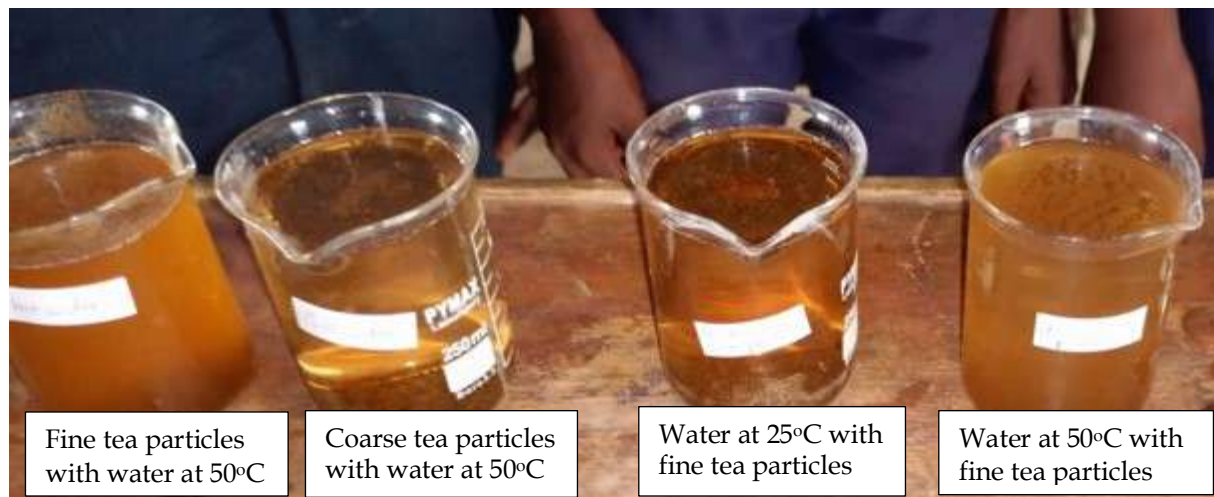

Figure 1: Set-up showing results of an investigating effect of size of molecules and temperature on diffusion

The results of this activity were very encouraging not just for me but also for students. Indeed, one student remarked, “Wow! *Mwalimu*, you mean that the tea we make is by diffusion?!” The student referred to me as *Mwalimu* which is Kiswahili for a teacher. But more important, it was clear from this remark that the student was able to relate the ideas in class to the everyday experiences – tea making process at home. My journey of developing practical activities that could engage learners and make them experience science had begun and there was no turning back.

This incident took place when we were just about to undertake a mid-term examination. I decided to include in the examination one question on diffusion just to gauge the students’ understanding of the idea of diffusion. The question I gave to the students is shown in the box below.

In an experiment to investigate factors that influence diffusion, a student prepared and used the following materials, coarse and fine crystals of copper sulphate, two 100ml beakers, a stopwatch, and water at room temperature.

i) What factor did the student intend to investigate? (1 mark)

ii) What was the purpose of the stopwatch? (1 mark)

iii) State and explain the results of the investigation for the factor named in (i) above (3 marks)

The total mark for the question was 5. On grading the students’ responses, I noted that none of the students scored a zero on the question unlike other questions involving content I had taught

using my usual method – textbook in hand and textbook prescribed activities. Table 1 shows the distribution of students’ scores on the diffusion question.

Table 1: Distribution of Scores for the Question on Diffusion

Marks	Frequency (N=38)	%
5	18	47.4
3-4	10	26.3
2	6	15.8
1	4	10.5
0	0	0.0

Conclusion

It is true that most areas in our biology syllabus are abstract and lack activities to make them clear to the learners. Other concepts have suggested activities in the books but the activities are also abstract themselves or too involving and out of touch for the average learner. It is, therefore, necessary for the teacher to be innovative and come up with activities that would help them teach biology through a practical approach while helping the learners to learn with ease. This also requires the teacher to be keen in determining which available activities may not work well for his/her situation and modify them to suit his/her needs. This way, the teacher will be helping learners to be active constructors of their knowledge. The learners are likely to develop the requisite 21st-century skills that include critical thinking and problem-solving, as well as communication and collaboration as espoused in the Competency-based Curriculum (CBC). Certainly, it may not always be an easy task to develop innovative activities or modify existing ones to make them relatable to students’ experiences but the outcome in the instructional practice outweigh the strain.

References

KLB [Kenya Literature Bureau] (2017), *Secondary Biology Form One Students book* (5th ed.), KLB, Nairobi, Kenya

Author Information

Kennedy Kivonya
Nguutani Secondary School
P. O. Box 338 90400 Mwingi
Kitui, Kenya
Email: kivsmania@gmail.com

An Interpretation of Universal Design for Learning and its Application in the Competence-Based Curriculum

Mungai Njoroge

Abstract

The competence-Based Curriculum (CBC) mission of *nurturing every learner's potential* has a rights-based quality education dimension that emphasizes the need for inclusion of all learners in the learning process. It places more responsibility of adaptation on the education system rather than the individual learner. The Universal Design for Learning (UDL) framework provides significant others in the education system, such as teachers and education administrators, with the necessary support to plan for learner-centered instruction. This aims at reducing barriers learners may face in the classroom and increasing access to opportunities to succeed in their learning. Through this article, I share an interpretation of UDL principles. The article gives examples of how to actualize the three principles of UDL to support the inclusion of all learners in the learning process.

Keywords

Competence-Based Assessment, Competence-Based Curriculum, Inclusive education, Meaningful learning, Universal Design for Learning,

Introduction

One cardinal duty of a teacher is to facilitate the implementation of quality education, which in the context of Universal Design for Learning (UDL) is characterized by the inclusion of all learners in the teaching and learning process at whatever level of schooling. The mission of the Competence-Based Curriculum (CBC) of nurturing every learner's potential has a rights-based quality education dimension that underscores this responsibility instituted upon teachers. Beyond teachers knowing what to teach and how to teach it, the quality transition of their knowledge to practice during instruction is an essential competency in facilitating meaningful learning by students. Significant interpretation of UDL can provide teachers with the necessary support in the implementation of their cardinal duty for the effective implementation of the CBC in Kenya.

Universal Design for Learning

The Universal Design for Learning (UDL) is an instructional framework based on scientific insights into how humans learn that targets to develop and enhance learning opportunities for all learners (Centre for Applied and Special Technology [CAST], 2018). UDL framework is structured around three principles: 1) provide learners multiple means of representation; 2) provide learners multiple means of action and expression; and 3) provide learners multiple means of engagement. The following are brief descriptions of each principal and a sample interpretation to support application by teachers.

1. Providing multiple means of representation to learners

The first principle is on providing learners *multiple means of representation* to enhance recognition networks, - The "what" of learning (CAST, 2018). It focuses us to reflect on flexible ways to present what we teach to support meaningful learning by all learners. To understand how this

principle works, let us consider an example of content in mathematics on how a teacher can guide students to work out the following question: “Mfugaji enterprise farm sells a day-old chick for KSh. 200 each in the poultry market. How much income is made if the farm sells 300 chicks?”

Three forms of mathematical representations (i.e., Graph, Symbol, and Table) can be used to guide students in determining the income made from the sale of the 300 chicks, as demonstrated in Figures 1 & 2 and Table 1.

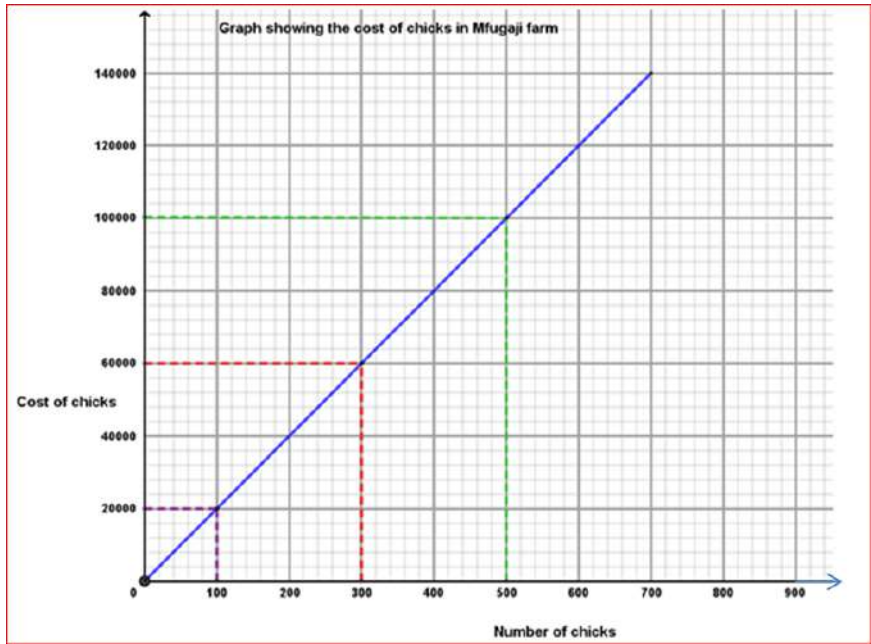

Figure 1. Graphical representation

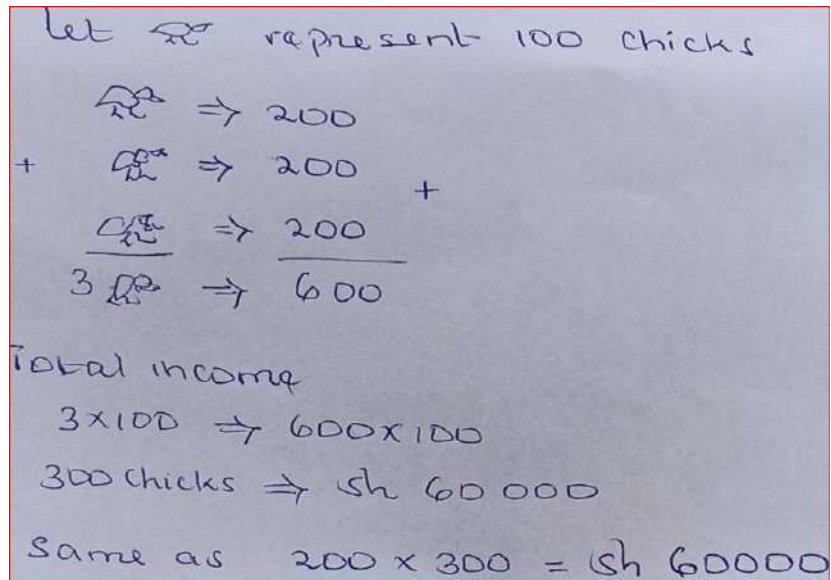

Figure 2. Symbolic representation

Table 1: Table representation

Number of chicks	Expression of chick cost (KSh.)	Total cost (KSh.)
1	200(1)	200
2	200 (2)	400
3	200 (3)	600
4	200 (4)	800
n	200 (n)	200n
300	200 (300)	60000

The three forms of representations present learners with a choice of alternative methods to determine the solution to the question. Importantly, learners are in a position to make sense of the solution based on the representation that best appeals to their reasoning. Visual learners may prefer graphs while logical learners may prefer table and symbol representations.

2. Providing learners multiple means of action and expression

The second principle is about providing learners *multiple means of action and expression* to sustain strategic networks – The "how" of learning (CAST 2018). This principle focuses us to reflect on flexible options for how we learn and express what we know.

In planning a lesson, a teacher ponders not only on how learners will show what they have



Figure 1: Aquaponic project for mixed crop cropping (Watermelon, Spinach and Nduma)

Source: Moi Girls Vokoli in Vihiga County

learned but how they will demonstrate mastery of learning – making learning visible. Teachers are encouraged to provide learners with choices, where necessary and appropriate, for demonstrating what they have learned. For example, teachers can provide learners an option to demonstrate their understanding of scientific phenomena (e.g., factors affecting pressure in liquid). Some learners can design an activity (or project) to demonstrate the application of a factor affecting pressure in the liquid. Figures 3 and 4 show sample projects students can engage in.

The projects in Figures 3 and 4 are based on Aquaponic farming

technology. Aquaponic farming relies mainly on water and substrates (sources of nutrients) added to the water to enable the growing of crops.

Learners can create (or source) digital content to demonstrate a similar understanding of the application of factors affecting pressure in liquids. Advancement in digital technology provides 21st Century learners with flexible and accessible environments to successfully take part in their learning and articulate what they know through digital tools (hardware devices and software applications). Consider various content youths are creating today mostly using handheld mobile devices and software applications, such as YouTube



Figure 2: Aquaponic project for rice farming

channels and social media applications (e.g., Tik Tok and Instagram). Digital literacy which is a key component of the CBC can be tapped and enhanced among learners through assignments and assessments that allow for their integration where applicable.

Providing students with opportunities to express their learning (e.g., through projects, oral submissions, or written tests) where applicable, then requires the use of a harmonized grading criteria. The grading criterion requires focusing on the learning outcomes rather than the format of assessment. For example, a rubric can support the assessment of the two ways (project design or digital project) that learners use to demonstrate their understanding of the application of factors affecting pressure in liquids.

3. Providing learners multiple means of engagement

The third principle is about providing learners *multiple means of engagement* to boost effective networks - The "why" of learning (CAST, 2018). This principle focuses us to reflect on flexible alternatives for supporting motivation to learn, such as tapping into learners' interests and challenging them appropriately. **There is no single means of learner engagement ideal for all learners in all contexts**; providing multiple alternatives for engagement is indispensable (CAST, 2018).

Linking concepts learned in class to the contextual application is one way that teachers can engage learners and support motivation to learn. Figure 5 illustrates ways learners may be in learning opportunities outside the classroom contexts.

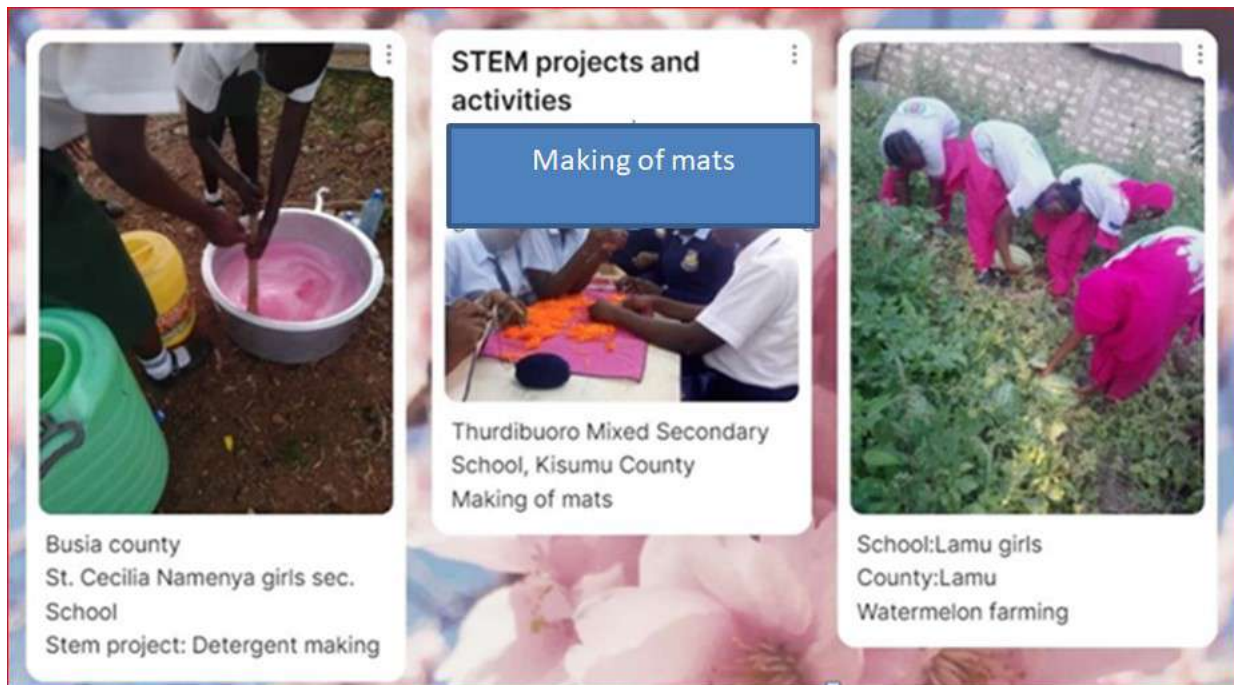

Figure 5. Learners engaged in outside the classroom learning opportunities

Figure 5 shows projects on STEM that were shared by Principals from St. Cecilia Namenya Girls, Thuridobuoro Secondary school, and Lamu Girls during a sensitization program for Principals from STEM Model schools organised by CEMASTEIA in 2021.

Outside the classroom learning opportunities, such as those illustrated in Figure 5, can prepare learners for future careers and solve problems that can lead to sustainable development. CBC considers this through aspects such as Community Service Learning (CSL) and Core Competencies (e.g., critical thinking and problem solving, imagination and creativity). Figure 6 gives a summary of the steps involved in Universal Design for Learning

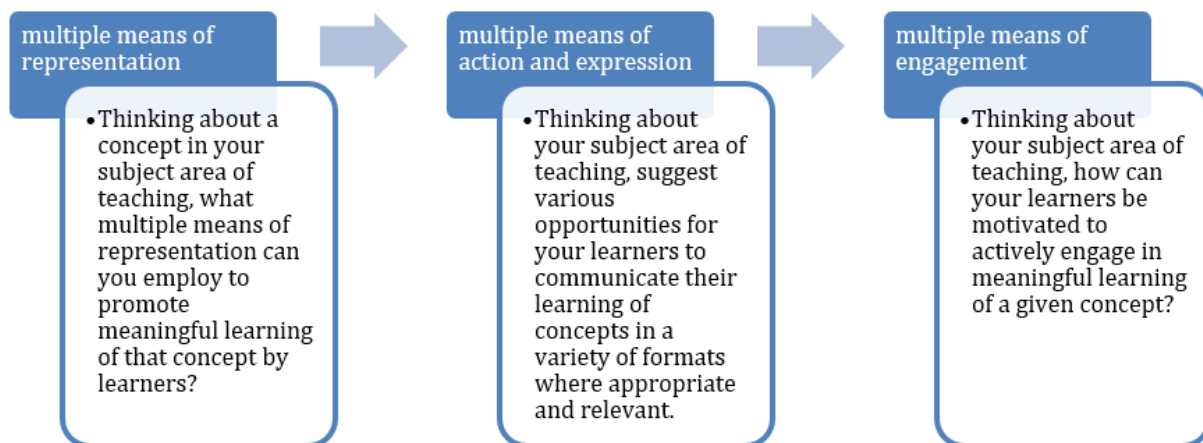

Figure 6: A summary of the steps involved in Universal Design for Learning

Conclusion

All learners must be included in the teaching and learning process. The Universal Design for Learning principles essentially supports this by guiding teachers on how to 1) contextualize instructional practices to mitigate barriers that learners may encounter in the classroom and 2) increase learners' access to opportunities to succeed in the learning process. This is important in supporting the realization of the Competence-Based Curriculum (CBC) mission of *nurturing every learner's potential*.

References

- Basic Education Curriculum Framework [BECF]. Retrieved <https://kicd.ac.ke>
- CAST [Centre for Applied and Special Technology] (2018). Universal Design for Learning Guidelines version 2.2. Retrieved January 5, 2022, from <http://udlguidelines.cast.org>
- CAST [Centre for Applied and Special Technology] (2022, January 5). *About Universal Design for Learning*. <https://www.cast.org/impact/universal-design-for-learning-udl>
- U-M Canvas. (2022, January 4). *Principles of UDL*. https://umich.instructure.com/courses/200/pages/multiple-means-of-action-and-expression?module_item_id=971506

Author Information

Mungai Njoroge
Centre for Mathematics, Science and Technology Education in
Africa (CEMASTEA)
P. O. Box 24214 00502 Nairobi
Email: jmungai@cemastea.ac.ke
mungainjoroge77@gmail.com



Vision & Mission

VISION

Excellent capacity development in STEM Education in Africa.

MISSION

To continuously develop competencies for sustainable development through STEM Education.

MANDATE & CORE FUNCTIONS

The Centre is mandated to provide continuous professional development of teachers in STEM education. The functions shall be to:-

- Provide training under policies specified by the Ministry of Education, TSC, and other relevant stakeholders;
- Conduct research to inform Teacher Professional Development programs, internal quality assurance processes, and policies;
- Organize and conduct seminars, workshops, conferences and symposia in STEM education and teacher capacity development;
- Print, publish and disseminate information and research related to STEM education and teacher capacity development;
- Provide advisory and consultancy services in STEM education and teacher capacity development;
- Develop local and international partnerships, linkages and collaborations with Government agencies, institutions and organizations with interests in STEM education and teacher capacity development;
- Function as the Secretariat of the Strengthening of Mathematics and Science Education in Africa (SMASE-Africa) Network and ADEA's Inter-Country Quality Node on Mathematics and Science Education (ICQN-MSE);
- Support the implementation of STEM in the Competency-Based Curriculum (CBC).

Vision & Mission

VISION

Excellent capacity development in STEM Education in Africa.

MISSION

To continuously develop competencies for sustainable development through STEM Education.

MANDATE & CORE FUNCTIONS

The Centre is mandated to provide continuous professional development of teachers in STEM education. The functions shall be to:-

- Provide training under policies specified by the Ministry of Education, TSC, and other relevant stakeholders;
- Conduct research to inform Teacher Professional Development programs, internal quality assurance processes, and policies;
- Organize and conduct seminars, workshops, conferences and symposia in STEM education and teacher capacity development;
- Print, publish and disseminate information and research related to STEM education and teacher capacity development;
- Provide advisory and consultancy services in STEM education and teacher capacity development;
- Develop local and international partnerships, linkages and collaborations with Government agencies, institutions and organizations with interests in STEM education and teacher capacity development;
- Function as the Secretariat of the Strengthening of Mathematics and Science Education in Africa (SMASE-Africa) Network and ADEA's Inter-Country Quality Node on Mathematics and Science Education (ICQN-MSE);
- Support the implementation of STEM in the Competency-Based Curriculum (CBC).

Quality Policy Statement

CEMASTEA is committed to providing continuous professional development of teachers in STEM education, and related services to its customers and stakeholders, in a timely efficient and effective manner

CEMASTEA is committed to satisfying customer, organizational, legal and ISO 9001:2015 requirements and to the continual improvement of its quality management system.